

ANAFI USA

WHITE PAPER

V1.5.3



APRIL 30, 2021
PARROT DRONES

Table of contents

- ANAFI USA in a glance4
- Conception.....5
 - Key characteristics5
 - Compactness5
 - Ruggedness6
- Aerodynamics9
 - Propulsion system9
 - Performances.....11
 - Quality11
- Imaging.....12
 - Triple camera module12
 - Key characteristics of the 3 cameras.....12
 - Continuous 1x to 32x zoom12
 - HDR13
 - Optical unit.....13
 - Diagonal (DFOV) and Horizontal (HFOV) fields of view13
 - Lossless zoom capabilities13
 - Angular resolution and discernable details14
 - Optical unit manufacturing: Active alignment14
 - Quality15
 - IR camera unit15
 - FLIR Boson performances15
- Coloring modes15
 - Relative mode16
 - Spot mode16
 - Media formats.....17
- IR/Visible blending17

- Security18
 - Integrity of the software and protection of the drone.....18
 - Network connections cyphering18
 - SD card encryption.....18
 - Data management.....18
- Video streaming.....19
 - Key characteristics.....19
 - Stream performance.....19
 - Video stream optimization algorithms used19
- Smart battery.....21
 - Key characteristics.....21
 - Performances.....21
 - Functions21
 - Smart power management.....21
 - Smart charging21
 - Wintering22
 - Stockage.....22
 - On-the-Go (OTG) USB-C Interface22
 - Power bank.....22
 - Charge indicator22
 - IP53.....22
- Quality23
- Flight control and flight modes.....24
 - Key characteristics.....24
 - Flight controller.....24
 - Components24
 - Sensor performance24
 - Motherboard coating25
 - Estimation algorithm25
 - Control loop25

Flight modes	26
Precise Hovering	26
Precise Return Home (RTH)	26
Smart RTH.....	26
Automated take-off	27
Hand take-off.....	27
Low altitude flight.....	27
Automated landing	27
Flying Modes.....	27
Manual:	27
Automated.....	28
FreeFlight 6.7	31
Key characteristics.....	31
HUD.....	31
Flight Plan user interface.....	32
Map backgrounds.....	32
Visualizing media	33
Automated updates.....	33
GSDK.....	33
ANAFI USA compatible tools	36
Pix4Dreact.....	36
Key characteristics.....	36
Kittyhawk.....	37
Survae	37
Planck Aerosystems.....	37
DroneSense	38
DroneLogbook.....	38
Skyward.....	38
Hoverseen	39

ANAFI USA in a glance

- 32x zoom
- 2 21Mp cameras (wide, telephoto)
- FLIR Boson® 320x256 IR camera
- 5-axes hybrid stabilization
- Compact: 228x101x76 mm
- Lightweight: 501 grams
- 32 minutes flying time
- IP53: dust and water resistant
- Discreet: 79 dB at 1 m height
- Speed: 14,7 m/s
- Operating temperature range: -35 °C à 43 °C
- Service ceiling: 6 000 m
- Video: 4K
- Deployed in less than a minute
- Hand-launch
- Hand landing



Conception

Key characteristics

- Ultra-lightweight: 501 g
- Folded (228x101x76 mm), ANAFI USA is ultraportable
- Functions in IP53 conditions for at least 32 minutes, a full battery flight

	
Unfolded (L x l x h)	282x373x84 mm
Folded (L x l x h)	246x104x82 mm
Weight	501 g
Unfolding	55 seconds
Operating temperature range	-35 °C/43 °C
Protection against solids/liquids	IP53

Compactness

Compact and lightweight, ANAFI USA weighs in 501 g for a 1.7-liter volume. ANAFI USA can be transported in a backpack or a case.

Fig. 1: Illustration of the compactness of ANAFI USA



ANAFI USA is the most compact drone of its category on the enterprise and military segments.

ANAFI USA unfolds in 3 seconds (Fig. 2). Its propeller blades system reduces its clutter, contrary to fixed pitch propellers.

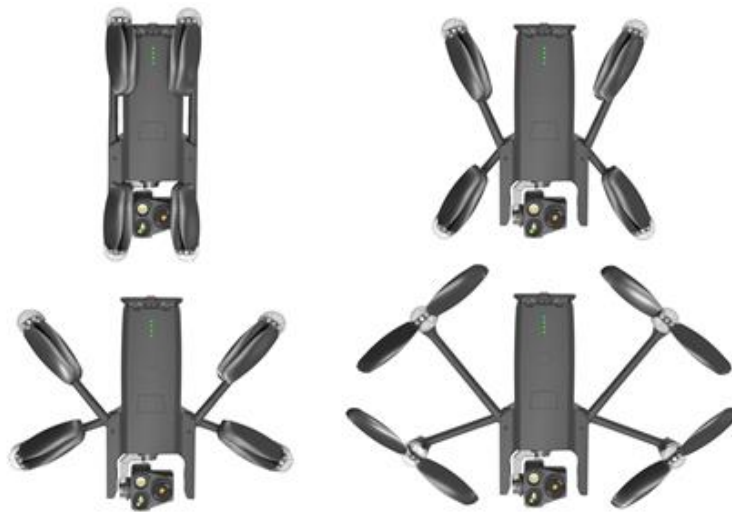
Fig. 2: Unfolding cinematic

Propeller replacement requires no tool: they just screw in the direction opposite to that of the rotation of motors, without risk of losing small mobile parts.

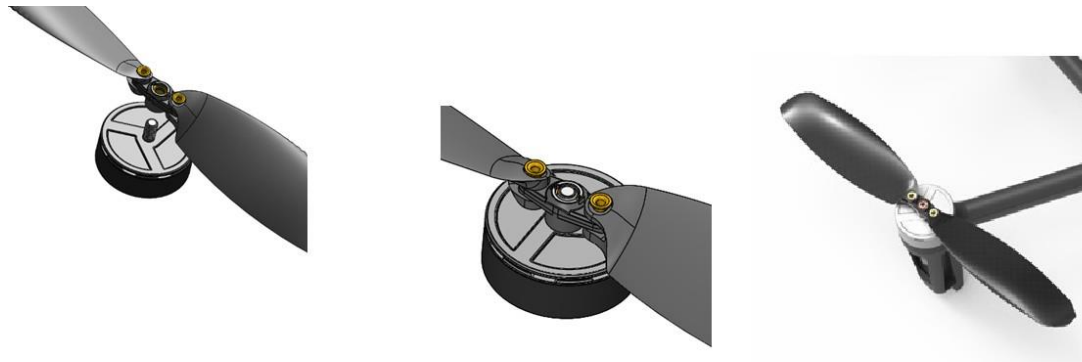
Fig. 3: Quick propeller install

Ruggedness

The mechanical structure of ANAFI USA is mainly made of polyamid, reinforced with carbon fiber and streamlined using hollow glass beads.

ANAFI USA motors are protected from dust, sand and rain by lateral vent-equipped covers, that enable the dispelling of heat.

Fig. 4: Motor covers

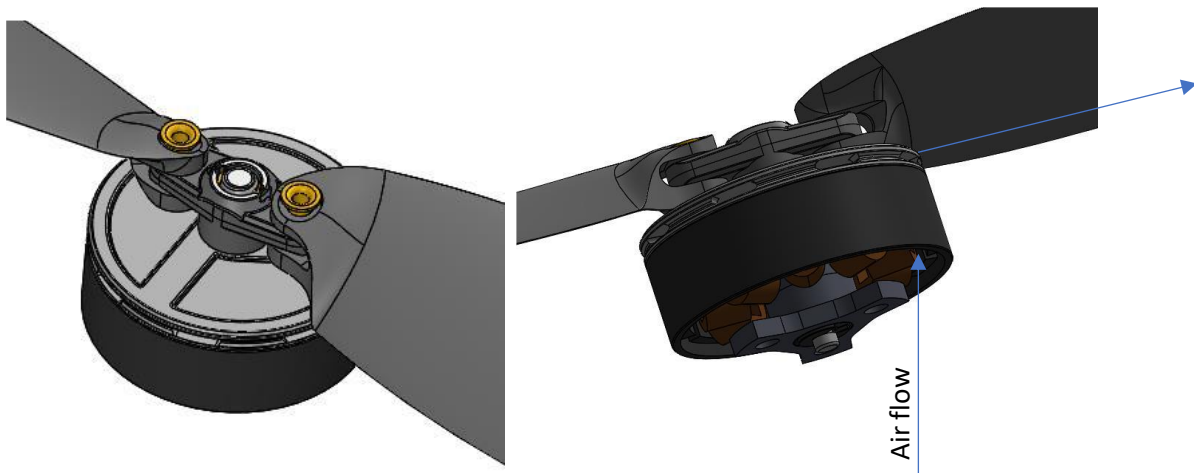

ANAFI USA's vertical camera and ultrasonar are protected from the rain by a collar which shelters both sensors.

Fig. 5: Vertical sensors protective collar



ANAFI USA has passed the following tests:

- IPX3 (CEI 60529 norm): rain resistant in IPX3 (10 liters/min) for the time of one battery charge (32 minutes) at least.

Fig. 6: IPX3 test (spraying 10 liters by minute)



- IP5X: dust resistant for at least 32 minutes (CEI 60529),

Fig. 7: IP5X test (sand)



- Damp heat (+40 °C and 93 % hygrometry) for 16 h (NF EN 60068-2-78)
- Dry heat (+50 °C) for 16h (NF EN 60068-2-2)
- Thermal shock: 20 1-hour cycles at -36 °C and +43 °C (NF EN 60068-2-14)
- Extreme temperatures: -20 °C and +70 °C for 4 h (NF EN 60068-2-1 & NF EN 60068-2-2)
- Low temperatures: -36 °C for 16 h (NF EN 60068-2-1)
- 92 flight continuous flight hours at ambient temperature, without mechanical wear
- ANAFI USA is functional after 18 falls (3 on each side) on concrete, from 1 meter high

Fig. 8: Falling test

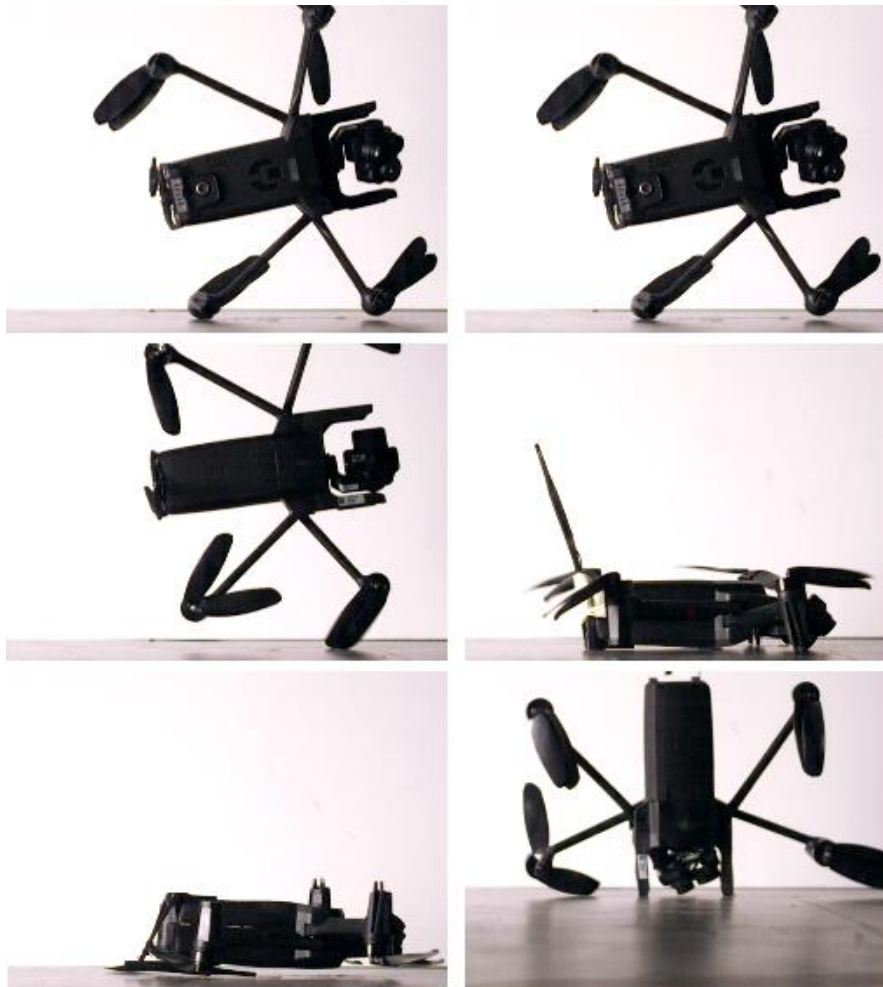

Aerodynamics

Fig. 9: Humpback whale fin



Propulsion system

- The blades of ANAFI USA's propellers have been conceived by biomimicry: they are inspired by the knobs of the anterior edge of the pectoral fins of humpback whales.
- Each propeller, consisting in two blades, is simply screwed on.
- From a flight perspective, ANAFI USA outperforms drones which are 1.5 times heavier and twice as cumbersome.

The advantages of "humpback whale blades"

- 1. The conception of the blade minimizes the transitory separation of the boundary-layer for each blade, to:*
 - a. recover thrust at constant motor rotation speed (rpm) - or alternatively to keep thrust while lowering the motor speed;*
 - b. minimize the sensitivity of the raising of mechanical power when blades twist.*

Therefore, with a lower rotation speed for a higher engine torque, ANAFI USA emulates a rotor whose power is higher than the theoretical capacity of its diameter.

- 2. The tonal sound power of the anterior edge of the blade, is minimized, lowering the noise of the flight.*

Fig. 10: ANAFI USA propeller blades



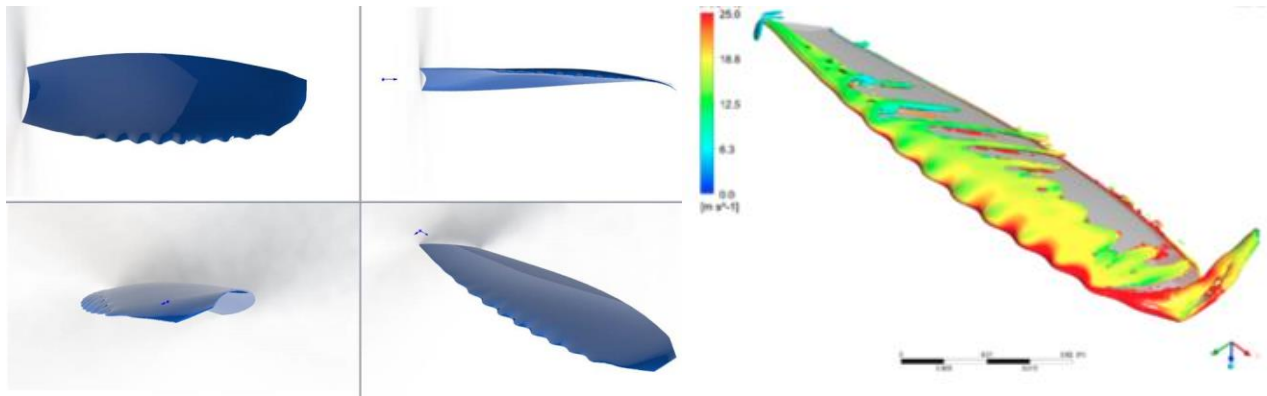

- ANAFI USA motors are powerful (46 W) with a 70 % yield (mechanical power divided by electrical power) when hovering; they have been conceived to optimize the blades' characteristics on the whole flight range.
- ANAFI USA has the best weight/flight time ratio of the industry: its 32 minutes flight time, its low weight (501 g) and the high yield of its conversion chain enable the drone to fly fast (54 km/h) and far (theoretical outreach: 17,4 km at 40,6 km/h).
- Wind resistance: 54 km/h
- Sound power: 79 dB

Performances

Aerodynamic performances	
Speed	14,7 m/s
Wind resistance	14,,7 m/s
Flight time	32 min
Max climb rate	4 m/s
Max rate of descent	4 m/s
Service ceiling	6 000 m (MSL)
Theoretical outreach	17.4 km
Max angular speed	300 °/s

Quality

- Parrot is ISO9001 certified.
- Every drone is controlled on a production bench (FVT).
- Bench #2: IMU thermal calibration plus barometer and magnetometer test.
- Bench #3: IMU & magnetometer dynamic calibration.
- Bench #4: motor disturbance measure on the magnetometer.
- Bench #5: ultrasound test.
- Flight test: every drone performs a flight test at the end of the production process: takeoff, hovering, landing.
- Numerous durability tests are performed in the course of our development cycles. These take the form of a quest for the optimal drone size.

Imaging

Triple camera module

ANAFI USA's gimbal shelters 3 gyrostabilized cameras: a wide angle EO 4K camera, a 32x telephoto EO 4K camera and a Long-Wave IR thermographic FLIR Boson® camera.

Fig. 11: Triple camera module

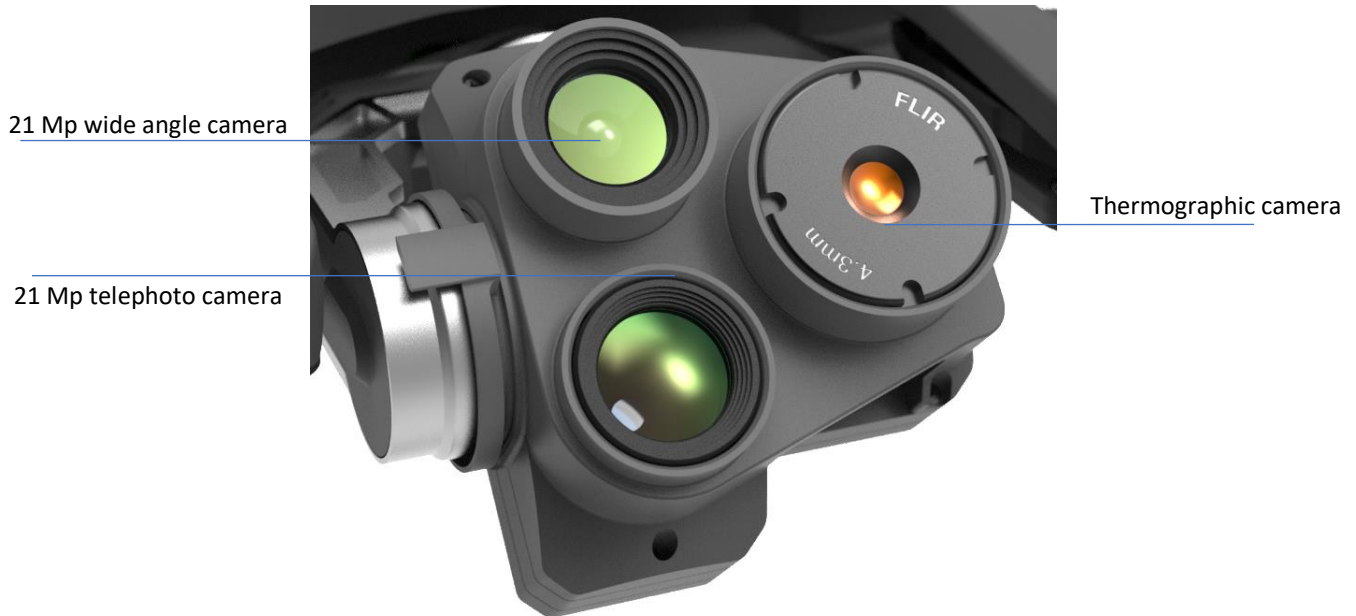

Key characteristics of the 3 cameras

- Wide angle EO camera
 - SONY IMX230 1/2.4"
 - RGB: 4K HDR (24 fps)
 - Photo: 21 Mp
 - Angular resolution: 0.016°/pixel
 - MTF > 45 % at 160 lp/mm
 - Zoom: 1x => 5x in 1080 p
 - F2.4 aperture
- Telephoto EO camera
 - SONY IMX230 1/2.4"
 - RGB: 4K HDR (24 fps)
 - Photo: 21 Mp
 - Angular resolution: 0.004°/pixel
 - MTF > 45 % à 160 lp/mm
 - Zoom: 5x => 32x in 1080 p
 - F2.4 aperture
- IR camera
 - FLIR Boson 320x256
 - Horizontal field of view: 50°

Continuous 1x to 32x zoom

The focal leap between the wide camera (1x to 5x) and the telephoto camera (5x to 32x) is automatic, which guarantees a continuous zoom.

Fig. 12: Zoom capability



Standard image

Zoom x32



HDR

The HDR algorithm restores up to 14 EV. The sensor exposes half of the pixels over a long period while the other half are exposed for a shorter period, avoiding artefacts due to movement. Both exposures are then fused to produce an image of the same definition as that native to the sensor (21MP) while optimizing contrast and reducing resolution loss in the finer details of the image.

The ISP defines exposure times depending on the scene as well as final image optimization (contrast, color, noise reduction).

Optical unit

We are using low dispersion aspheric lens architectures (110° and 26° diagonal fields of view, respectively for the wide and tele lenses). The optical units are composed of six lenses optimized to minimize the level of parasitic light while providing a high-resolution image across a vast temperature range (-43 °C to 45 °C).

Diagonal (DFOV) and Horizontal (HFOV) fields of view

The lens of the wide camera covers the full diagonal of the sensor with a 110° DFOV. It brings a 69° HFOV for the standard video mode, and a 75° HFOV for the standard photo mode.

The lens of the tele camera covers the full diagonal of the sensor with a 26° DFOV. It brings a 16° HFOV for the standard video mode, and a 16° HFOV for the standard photo mode.

Lossless zoom capabilities

The conception of ANAFI USA's optical unit enable the drone to achieve 5x lossless zoom in 4K-UHD (3840x2160 px), 10x lossless zoom in Full HD (1920x1080 px) and 15x lossless zoom in HD (1280x720 px). Finally, at 27x zoom, ANAFI USA images still reach DVD quality (720x480 px).

Angular resolution and discernable details

The angular resolution of a lens expresses the angular separation between two pixels of the associated sensor. With the angular resolution of 0.004° on its telephoto lens, ANAFI USA enables its users to discern 10 cm (about 4") details at a distance of 1,500 m (about 0.93 miles), or 1 cm (about 0.4") details at 150 m (about 164 yards).

Fig. 13: Architecture of an ANAFI USA optical unit



Optical unit manufacturing: Active alignment

The optical unit is assembled with the Sony sensor using an Active alignment technique. The optical block is positioned and held in place using a robotic arm, to achieve the following performance:

- the optical block is positioned above the sensor to ensure the desired focus at a set temperature (23 °C +/- 2 °C) and to guarantee resolution specifications in the scene;
- in yaw, roll and pitch, the optical block is position respecting the optical axis to obtain a uniform resolution on the edge of images;
- the sensor is aligned with the optical block axis to get the best performance at the center of the image;
- the optical center is finally aligned with the sensor center (+/- 20 pixels or 22 micrometer).

To guarantee the ISP's image quality specifications, the factory performs an image calibration. In its internal memory, each optical unit carries the optical center, a dead pixel mapping, a lens shading mapping (luminance and color) and white balance.

Fig. 14: Active alignment

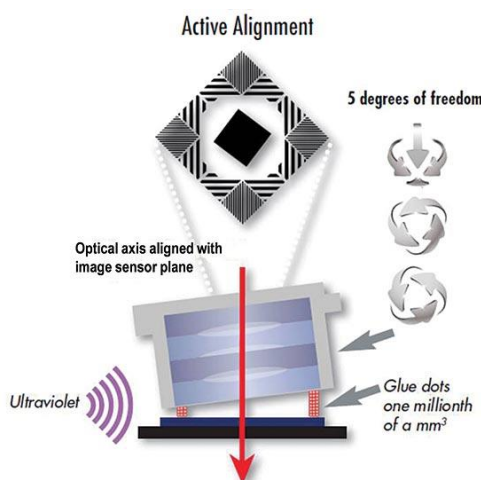

Quality

Several optical tests are performed in the course of the production process:

- MTF checks on the image center
- MTF checks on the image borders
- Camera module checks while in production:
 - Center MTF
 - MTF at 40 % of the field
 - MTF at 70 % of the field
 - Light blemishes (dark or light areas on the image, dust suspicions)
 - Dead pixels (checking the total number)
 - Optical center
 - Uniformity of brightness and color in the field
- Cosmetic defects (stains, scratches, etc.)

IR camera unit

IR camera performances	
Spectrum	Longwave infrared : 8 to 14 micrometers
Resolution	320x256 pixels
Pixel pitch	12 micrometers
Sensitivity	0.05 °C
Focal length	4.3 mm
HFOV	50°
Frequency	20 Hz
Measurable temperature range	-40°C à 180°C
Correction of discrepancies	Mechanical shutter

FLIR Boson performances

ANAFI USA carries a 60 Hz FLIR Boson micro-bolometer. This module is equipped with a mechanical shutter which enable automatic recalibration of the sensor as often as possible, for a complete consistence of each thermal pixel's response. The lens of the FLIR Boson has a 50° HFOV.

Coloring modes

ANAFI USA's thermographic camera presents two complementary coloring modes, which enables the drone to adapt to every mission.

Relative mode

The relative mode displays a general view of the thermographic of a scene, on a colored scale, graduated from 0 (dark blue) to 100 (bright yellow).

Fig. 15: Freeflight 6.7 screen capture: "relative mode"



Spot mode

Only coldest or hottest spots of the image are colored, depending on the user's needs.

Fig. 16: Freeflight 6.7 screen capture: "Spot mode"

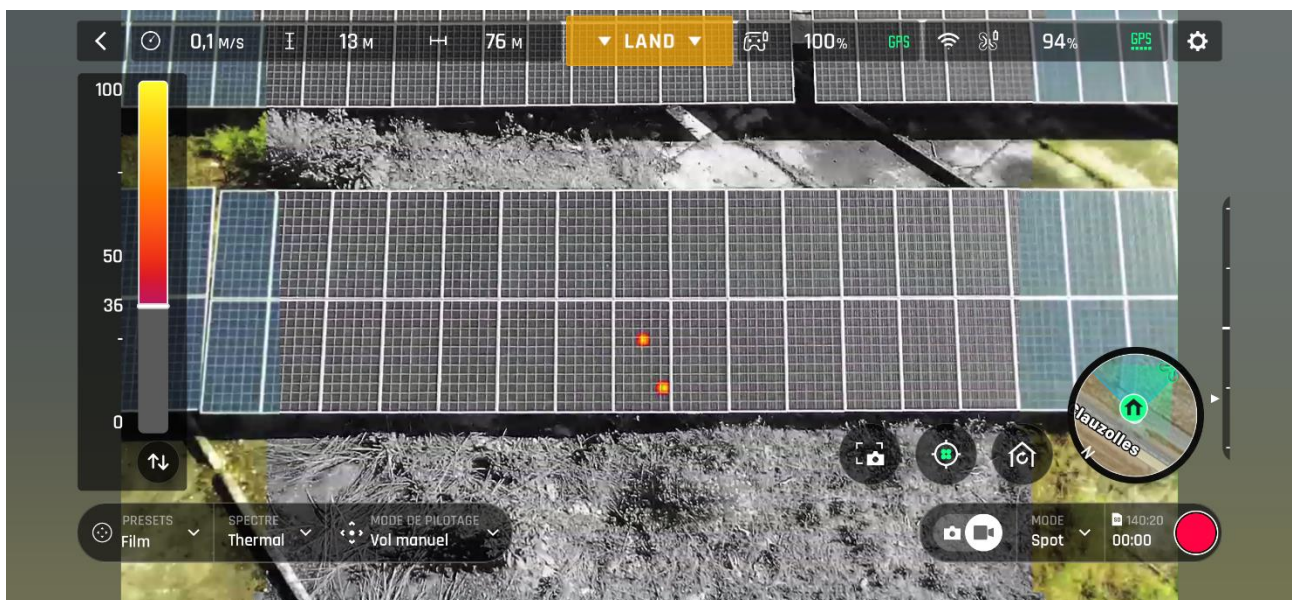

Media formats

ANAFI USA produces the following media formats:

- Photo:
 - Format: JPEG
 - Resolution: 1280x720
 - Modes: single / Timelapse / GPS-lapse
- Video:
 - Format: MP4 (H264)
 - Resolution: 1280x720, 9 fps

IR/Visible blending

To compensate the lower resolution of the thermographic image, by comparison with the visible image, and to add information that are not available through the thermal spectrum, ANAFI USA displays a fusion of the information of the two cameras. The data of the visible image is injected in the outcome footage, by luminance and to highlight the scene's contours.

The fusion of images consists in:

- acquisition of visible image;
- acquisition of thermographic data;
- reprojection of thermographic data;
- colorization of thermographic image;
- extraction of visible images contours;
- mixing.

Security

ANAFI USA protects the data stored on the drone or sent to the networks and shelters the drone against malevolent software modification attempts.

Integrity of the software and protection of the drone

ANAFI USA's software is digitally signed, which ensures that each update indeed comes from Parrot.

The access to ANAFI USA's operating system is protected. No mechanism, neither local nor distant, give access to the drone's embedded system.

Network connections cyphering

The network links between the drone and its controller are authenticated and cyphered with a WPA2 (802.1x norm) protection. WPA2 is based on an AES CCMP cyphering, including a 128 bits encryption key. AES CCMP includes a CBC-MAC mechanism which ensure the authentication and the integrity of the network's links.

A unique encryption key is generated for each drone/controller couple. In addition, users can define their own key.

The protection of the 802.1x management framework is activated to prevent all known disassociation attacks, which could cause service interruption.

SD card encryption

The encryption of the SD card protects the confidentiality of data stored on the drone, even if it is lost or stolen.

Once the encryption is activated, the videos and photos are stored in an AES-XTS 512 bits-encrypted LUKS2 volume. The use of a unique identifier for each container enables the management of a fleet of SD cards which can be used on several drones.

Once the SD card is encrypted, it can never be accessed without the encryption key. It is carried by FreeFlight 6 and is never stored permanently on the drone.

Data management

By default, ANAFI USA, the controller and FreeFlight 6 leak no data whatsoever, neither toward Parrot, nor anywhere else. Each user must decide to activate the sharing of its data to store his flight logs online, facilitate the support of his drones and help Parrot product and services improvement. To share his data anonymously or to link them to his Parrot account, the user must activate the sharing of his data, that is deactivated by default.

Video streaming

Key characteristics

- H264 encoding with RTSP and RTP transmission protocols
- The video stream is compatible with RTP-compatible players, like VLC or mplayer
- 720p, 30 fps, 5 Mbit/s
- Advanced video and streaming functions, for an improved error resilience
- Compatible with the following standards: ISO/IEC 14496-10 AVC / ITU-T H.264, RFC 3550, RFC 2326
- Reduced latency (< 300 ms glass-to-glass)
- Metadata transmission: telemetry, video metrics

Stream performance

<i>ANAFI USA Video stream performance</i>	
Resolution	720p
Frames per second	24/25/30
Bitrate	Up to 5 Mbit/s
Video encoding	H.264 main profile
Protocols	RTSP and RTP (VLC compatible)
Latency	< 300 ms glass-to-glass
Metadata	Drone telemetry and video metrics

Video stream optimization algorithms used

Advanced encoding for Error resilience

The H264 stream is designed to minimize the impact of packet losses and to dilute errors.

- The algorithm combines slice-encoding and a periodic intra-refresh. It encodes images as 45 slices of 16 pixels height, then refreshes them by batch of 5, every 3 images (the refresh is complete every 29 images).

Error concealment

This algorithm reduces the visual impact of losses on the network and it enables the interoperability of all decoders, while ensuring a syntactically complete stream: missing images parts are reconstructed as skipped portions, identical to those of the reference image.

The glitches are therefore contained within zones impacted by losses, and do not spread to the entire image.

The following graphs illustrate the rate of success in decoding macroblocks, for a network loss rate of 5% - with and without ANAFI USA's advanced streaming functions. The algorithm ensures a correct decoding for 75% of the macroblocks. Those enable the user to carry on with his missing without screen freeze or streaming loss.

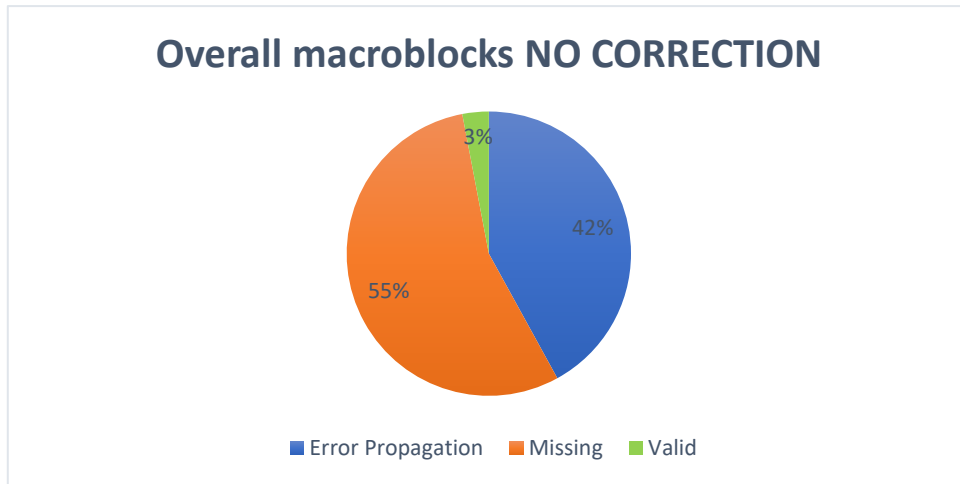

Overall macroblocks WITH CORRECTION

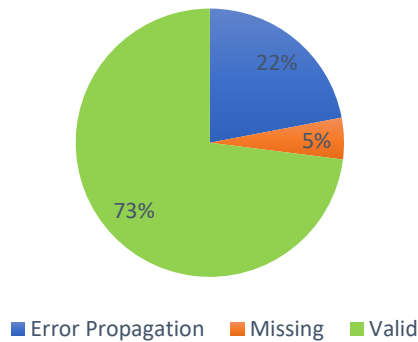

Congestion control

The algorithm consistently scans radio and Wi-Fi bands to avoid losses and packet congestion and to reduce latency.

Metadata

Metadata are transmitted with the video stream. They notably contain drone telemetry elements (position, altitude, speed, battery level, etc.) and video metrics (angle of the camera, exposure value, field of view, etc.).

The synchronization of the images and the metadata open functions as precise map positioning, flight instrument tracing within the HUD or augmented reality elements inclusion.

The inclusion of metadata is using standard methods (RTP header extension); the format of the data, defined by Parrot, is public: it is available within ANAFI USA's SDK.

Video SDK

The streaming tools and algorithms used by ANAFI USA are publicly available within Parrot's Ground SDK, supported by mobile devices (Android and iOS) and computers (Linux, Mac OS).

The "error concealment" algorithm notably opens the possibility to develop new software, taking profit of and improved video quality - by comparison to standard video players.

Smart battery

Key characteristics

- 3 High Density cells (265 Wh/kg)
- Smart Power Management
- Smart Charging; inbuilt USB-C charger
- Wintering mode: automatic discharge and inactivation to prolong the battery life
- Black Box: inbuilt battery history
- IP53 protection

Performances

Weight	195 g
Density	205 Wh/kg
Charging time	112 minutes (USB-PD – Power Delivery – charger)
Type	High density, high voltage; 4,4 V
Cells	3 x LiPo
Capacity	3400 mAh
Charger	USB-C
Cycle Life	96 % capacity remaining after 300 charge/discharge cycles
Storage temperature	-20 °C / 40 °C
Minimal take-off temperature	-20 °C
Maximal take-off temperature	60 °C

Functions

Smart power management

ANAFI USA's battery integrates a power gauge which accurately monitors, every 250 ms, the battery voltage, the charge and discharge currents, and the battery temperature. The battery determines the available charge, battery run time, and battery state-of-charge (SOC) using the gauge parameters, the age of the battery, as well as its state-of-health. The state-of-health of a battery is a figure of merit of its current condition relative to its nominal capacity -3400 mAh.

The accurate control of battery parameters allows the integration of the Smart RTH feature: ANAFI USA calculates in real time the amount of energy necessary (critical threshold) to return to its take-off position. ANAFI automatically returns to its take-off point when the battery reaches the critical threshold.

Smart charging

ANAFI USA's battery charges easily and quickly with any USB-C adapter, thanks to its industry-first 26 W inbuilt charger. It is compatible with USB Power Delivery (PD) 3.0 protocol. This protocol enables a very fast 112 minutes charge with an USB-PD 3.0 charger (5 V, 9 V, 12 V, 15 V and 20 V profiles). ANAFI USA comes with a 5-port charger, to charge 3 batteries, the Skycontroller 3 and a device (smartphone or tablet) at the same time.

Wintering

After 10 days of inactivity, the battery automatically enters wintering mode, which keeps the battery at an optimal state-of-charge (60 % of the nominal charge) in order to extend its lifetime.

This mode ensures the best possible preservation when batteries are stored. It eliminates leakage current by isolating the cells from the motherboard, thus avoiding a weak voltage level to be drawn (3 V) that would damage the battery.

Stockage

The battery can be stored for 12 months as is, by maintaining the voltage across the cell terminals at a higher voltage level (3 V) than the deterioration voltage.

On-the-Go (OTG) USB-C Interface

The battery's USB-C port can provide power (3 A maximum) to an external peripheral such as a 4G key, a CO² detector or any type of USB-C connected electronic board.

Power bank

The battery can be used as a power bank for many types of devices (smartphone, tablet, etc.).

Charge indicator

The 4 LED of the battery indicate its charge level in the following situations:

- when the battery is charging;
- when its power button is activated;
- when it is installed on a powered-on ANAFI USA.

The charge level is an illustration of the remaining available power, expressed as a percentage of the total power the battery can store.

IP53

ANAFI USA's battery was designed to sustain IP53 conditions: mechanical waterproof cover and electronic board coating to avoid oxidation.

Mechanical

Fig. 17: Waterproof mechanical cover

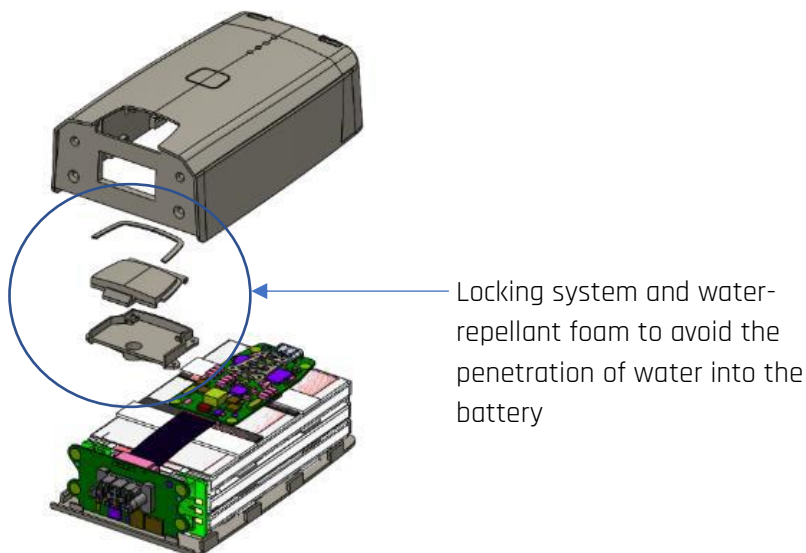

Electronic board coating

ANAFI USA's battery's motherboard is coated with a fine layer of urethane which protects the components from weather and corrosion, prolong their life and improve their safety.

Quality

- Parrot is ISO9001 certified
- The batteries are CE and FCC certified
- The batteries are UM383 certified (transport certification)
- Quality control at the battery supplier facility: Parrot has imposed a reinforced quality control on battery production (supplier audit, QC controls), including test benches which monitor the assembly at each production stage.
- Manufacturing control: Parrot performs quality checks at the drone manufacturer facility. Every battery is checked on a test bench during production, on a wide series of parameters: voltage, current, impedance, smart battery and wintering functions.
- Parrot performs random sampling to check cell quality (folding, assembly and connectors), using X-ray and tomography.

Fig. 18: X-ray image of ANAFI USA's battery



- Storage checks: the state of batteries (state-of-charge) stored by Parrot is controlled every 4 months.
- Firmware update: the battery's firmware is updated over the air (OTA) to provide the latest improvements and the bug corrections.
- Wintering mode prevents the battery from degrading while reducing storage risks.
- FreeFlight 6.7 notifies the user in case of battery defect.

Flight control and flight modes

Key characteristics

ANAFI's flight controller offers an intuitive and easy flight experience: no training is required to fly. The flight controller allows the automation of numerous flight modes and functions (Flight Plan, Follow Me, Cameraman, Hand take-off, Smart RTH).

Flight controller

Components

ANAFI USA's flight controller uses an Ambarella H22 processor, an MPU-6000 Invensense IMU, an AK8963 AKM magnetometer, an UBX-M8030U-BLOX GPS, an ultrasonar, a barometer and a vertical camera. The Parrot flight software gathers data from all sensors to estimate the altitude, the position and the speed of the drone.

Sensor performance

Invensense MPU-6000 IMU

3-axis gyroscope

- Range: $\pm 2000^\circ/s$
- Resolution: $0,03^\circ/s$
- Bias/accuracy: $\pm 7^\circ/s$ (after compensation)
- Stabilization at temperature ($50^\circ C$)

3-axis accelerometer

- Range: $\pm 16 g$
- Resolution: $0,2 mg$
- Bias/accuracy: $\pm 15 mg$ (X-Y) $\pm 67 mg$ (Z) (after compensation)
- Thermal calibration and stabilization at temperature: $50^\circ C$ to $\pm 0,1^\circ C$
- Measured frequency: $1 KHz$

ST Microelectronics LIS2MDL magnetometer

- Range: ± 49 gauss
- Resolution: $0,006$ gauss

ST Microelectronics LPS22HB barometer

- Range: $260-1260 hPa$
- Resolution: $0,0002 hPa$
- Bias/accuracy: $\pm 0,1 hPa$
- Measuring frequency: $75 Hz$
- Measure noise: $20 cm RMS$

U-BLOX UBX-M8030 GPS

- Sensitivity: cold start = $-148 dBm$ / tracking & navigation = $-167 dBm$
- Time-To-First-Fix: 35 seconds
- Position: $1,2 m$ standard deviation
- Speed: $0,5 m/s$ standard deviation
- GPS, Glonass and Galileo constellations activated*

*Beidou is not activated.

Ultrasonar (height measurement)

- Sonic frequency: 40 KHz
- Measuring frequency: 17 Hz
- Max range on concrete: 5 m
- Max range on grass: 2 m

Vertical camera (measuring horizontal speed and height using optical flow)

- Sensor: MX388
- Resolution: 640x480
- Global shutter
- Black & white
- FOV: 53,7°
- V FOV: 41,5°
- f:2.8
- Optical flow at 60 Hz to calculate ground speed
- During hovering and precise landing, points of interest are measured at 15 Hz
- Speed estimation: 160x120 pixels - 60 fps
- Precise hovering: 160x120 pixels - 15 fps

Motherboard coating

ANAFI USA's motherboard is coated with a fine layer of urethane which protects the components from weather and corrosion, prolong their life and improve their safety.

Estimation algorithm

It estimates the states of the drone. An extended Kalman filter collects all sensors data to monitor 18 physical states:

- speed on all 3 axes (x, y, z)
- attitude ($\Phi\Theta\Psi$: pitch, roll, yaw)
- accelerometer bias (x, y, z)
- gyroscope bias
- barometer bias
- x, y, z position in the North-East-Down (NED) plane
- wind on x, y in the NED plane

The magnetometer bias on x, y, and z is estimated by merging data from the gyroscope and magnetometer.

Ground distance is estimated by merging the Kalman filter estimated vertical speed and the optical flow from the vertical camera.

The thrust model's correction factor is calculated from the delta between the acceleration predicted by the drone's dynamic equation on z-axis and the accelerometer sensed value. This factor allows the calculation of the drone's balance control in order to compensate for its own weight.

Control loop

The control loop runs at 200 Hz. It manages all instructions sent to the motors, including all commands linked to altitude, positioning, attitude and control blending.

Altitude instructions

- Trajectory and feedforward generation uses an ideal model: it dissociates trajectory dynamics from disturbance rejection while reducing altitude control errors
- PID type altitude control

Position control loop

- Trajectory and feedforward generation using an ideal model: it dissociates trajectory dynamics from disturbance rejection while reducing positioning control errors
- PID type position control
- Wind correction

Attitude instructions

- Trajectory and feedforward generation using an ideal model: it dissociates trajectory dynamics from disturbance rejection while reducing attitude control errors
- PID type attitude control
- Aerodynamic torque compensation
- Estimation of external torques

Commands blending

- Blending of altitude and attitude commands allow to derive motor instructions and their saturation
- Commands are prioritized in the following order:
 - Pitch
 - Roll
 - Altitude feedforward
 - Yaw
 - Altitude

Flight modes

Precise Hovering

While hovering, the drone's vertical camera captures a reference frame. It is then compared to subsequent shots taken at 15 Hz. The algorithm calculates the camera movement that would minimize the reprojection error between the reference photo and more recent one. This movement is then used as an instruction for the autopilot.

ANAFI is stable within a 1.5 cm radius-sphere at 1 m height.

The algorithm also allows for yaw stabilization and contributes to the overall image stabilization performance.

Precise Return Home (RTH)

At the end of the take-off sequence, the vertical camera takes a picture. When the drone lands, or hovers above the RTH target, the algorithm takes a new picture. The algorithm then measures the reprojection error between the two pictures, which serves as an instruction for the autopilot.

Smart RTH

The drone keeps track of the amount of energy needed to return to its take-off position. It analyzes the distance already flown as well as the wind resistance encountered and compares these values with the remaining energy of the battery. When only a thin safety margin is left, the RTH function is automatically initiated - which can be cancelled by the user.

Automated take-off

The drone stabilizes at 1 m height, hovering. It uses its GPS and vertical camera to hold its position, even despite strong winds.

Hand take-off

The drone's motors start rotating at minimal speed and wait to detect the launch. It then stabilizes at the same height at which it was launched.

Low altitude flight

The drone can fly as low as 50 cm from the ground without experiencing ground effect.

Automated landing

Regardless of the drone's altitude, when the remaining energy of the battery is close to that needed to land safely, the emergency automated landing sequence initiates. The user can still control the drone horizontally to reach a convenient landing spot, but he cannot cancel the landing.

Flying Modes

Manual:

The Parrot Skycontroller 3 allows you to fly in four different control modes.

	Left joystick	Right joystick
Mode 1	Elevation & rotation	Direction
Mode 2	Direction	Elevation & rotation
Mode 3	Acceleration & rotation	Elevation & rotation
Mode 4	Elevation & rotation	Acceleration & rotation

Automated

Follow Me

The user selects himself on the screen (double tap or tap & drag). ANAFI follows the user from up to 30 m away.

Fig. 19: Follow Me screenshot

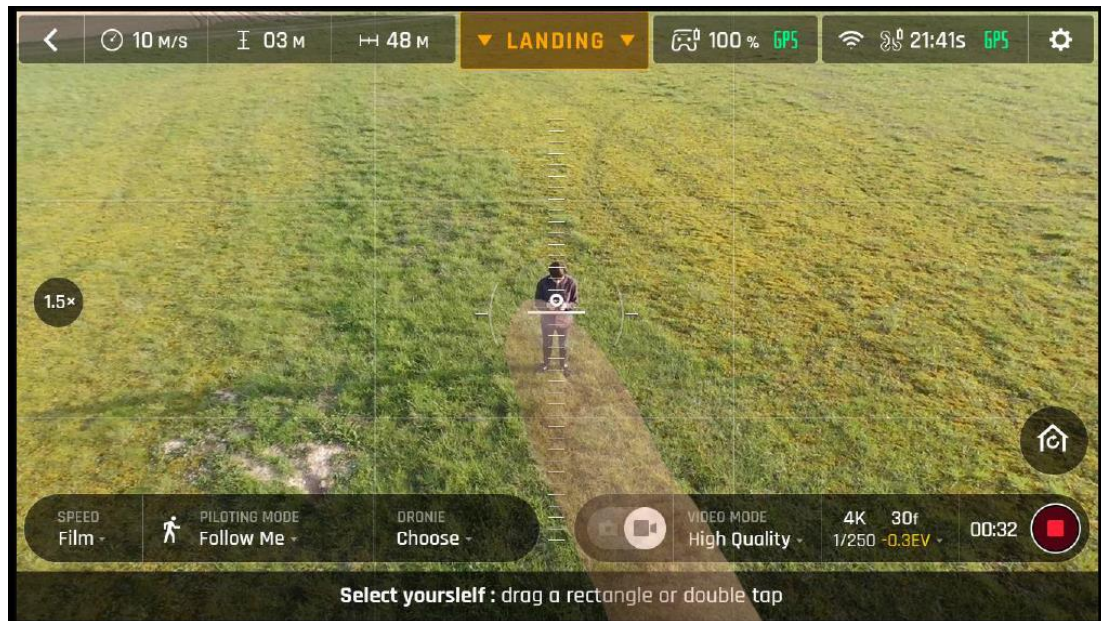

The Follow Me mode combines visual and GPS tracking algorithms.

Visual tracking combines:

- 1) a motion model of the target's position in relation to the drone's position;
- 2) a visual tracking algorithm (optical flow and online learning based on SVM);
- 3) a target segmentation algorithm.

The SVM algorithm initiates tracking with a single shot and keeps updating target recognition. The algorithm can manage changes in the silhouette of the target – for example, the algorithm follows the directional changes of a moving vehicle (side view followed by rear view).

The algorithm is robust: the convolutional neural network identifies objects within the scene regardless of the orientation of the tracked silhouette. Its use is optimized for portable devices.

This convolutional neural network is trained on public VOC and COCO databases and fine-tuned on a Parrot drone images database, ensuring the highest level of reliability.

This neural network can detect cars and pedestrians:

- Target height > 1/3 the image: 100 % detection level
- Target height > 1/8 the image: 66 % detection level
- Target height > 1/15 the image: 50 % detection level

Finally, a Kalman filter performs the GPS/Vision merging.

Cameraman

This mode implies selecting a target (person, vehicle, building, animal, etc.) on the screen (double tap / tap & drag). When activated, the camera keeps the target framed (roughly 30 m range, depending on the size of the target).

The visual tracking is based on the same algorithm as the Follow Me mode.

The algorithm (neural network and proprietary AI) adapts to the evolution of the shape and directional changes of the target.

The pilot concentrates on the flight while the camera automatically adapts its framing (pitch and yaw) to keep the target in its frame.

Touch & Fly

The Touch & Fly flight mode enables the user to define the destination of the drone with a simple touch on the screen. The GPS coordinates of the selected location are transmitted to the drone.

Fig. 20: Touch & Fly screenshot

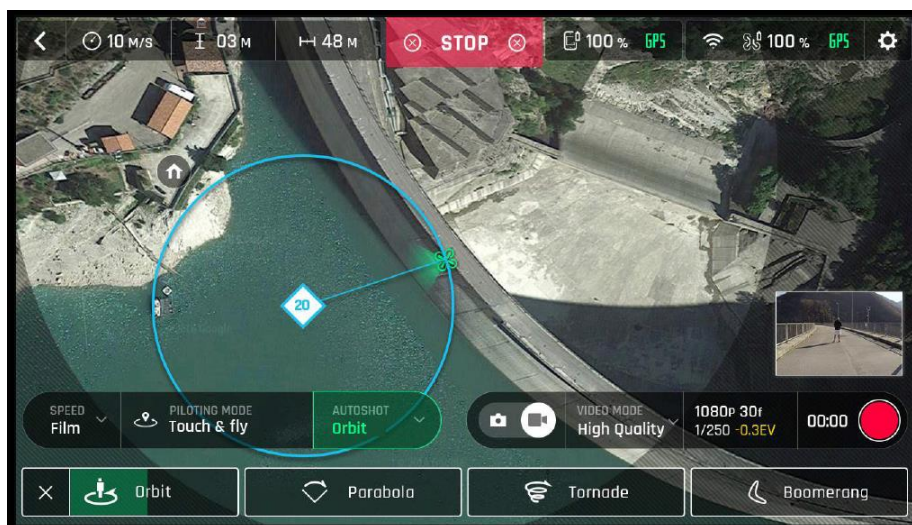

Flight Plan

The Flight Plan function of FreeFlight 6 enables users to prepare their missions offline, directly on their screen of their device by selecting waypoints, altitude and camera axis. Parrot has simplified the ergonomics of mission planning, which is usually a complex task. Each flight plan can be saved and edited without limitation.

A flight plan is possible even without radio connection.

Fig. 21 Flight Plan screenshot

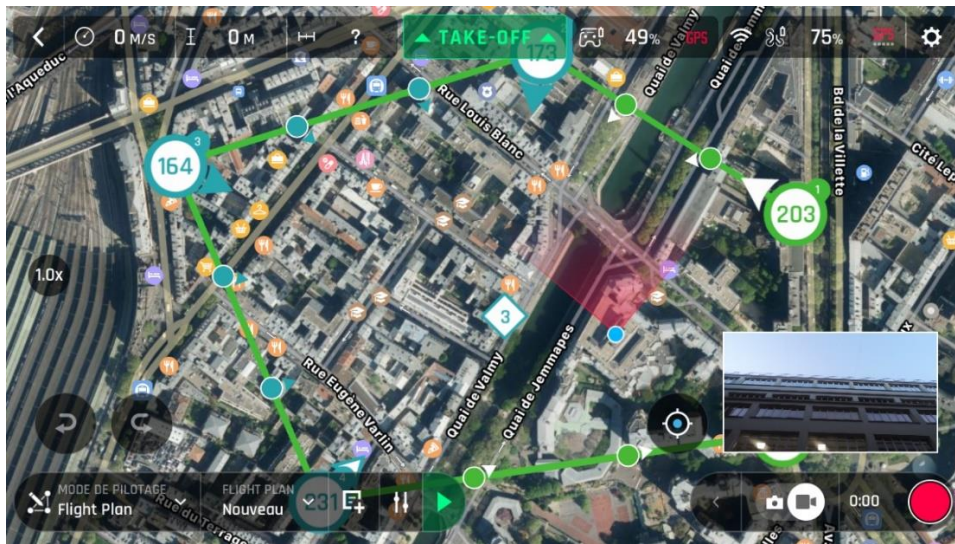

Automated flight

The Cineshot function of FreeFlight 6.7 carries 4 automated shots (360, Reveal, Spiral, Epic). Parrot can also program and automate specific flight sequence-shots upon request.

FreeFlight 6.7

Key characteristics

- FreeFlight 6.7 is not only a drone piloting application, but a complete interface from which users select all their flight, photo and video settings. It can be used in conjunction with the Parrot Skycontroller 3 controller or without, in a device only set-up.
- ANAFI USA is ready for flight in 55 seconds, an industry-best for a drone of this category.

HUD

The HUD (Head-Up Display) is the ergonomic interface of FreeFlight 6, presenting flight controls, settings and telemetry on a single screen:

- Altitude
- Distance
- GPS
- Drone battery level
- Controller battery level
- Radar

Fig. 11: FreeFlight 6.7 interface

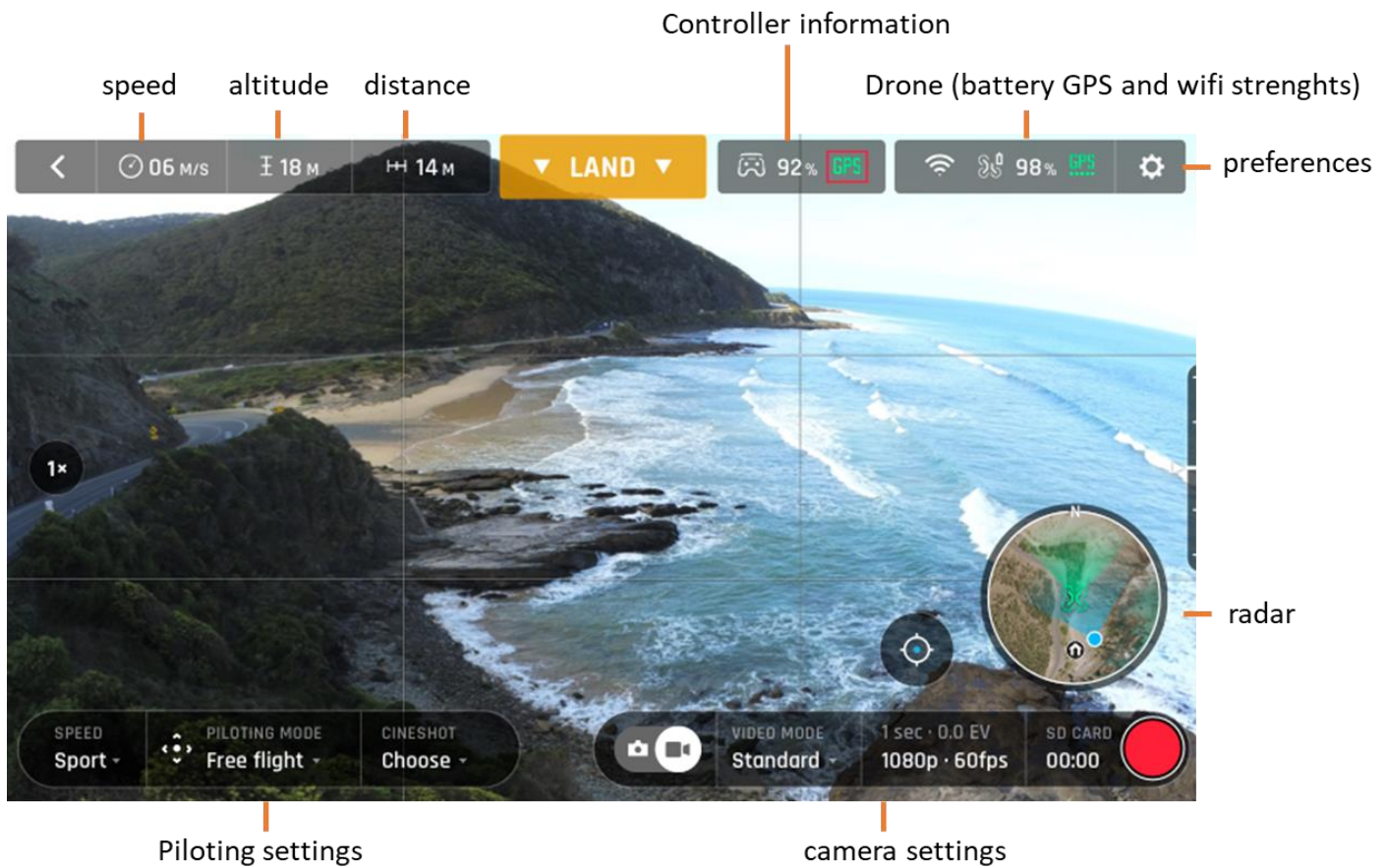

Flight Plan user interface

Each Flight Plan is programmed using waypoints.

The altitude and camera axis of each waypoint is customizable. The drone speed can be modified between each waypoint. The camera axis can be oriented toward a Point of Interest (POI), forcing the drone to focus on the POI during the flight.

Note: there is no software limitation on the number of Flight Plans that can be recorded.

Fig. 23: Flight Plan screenshot

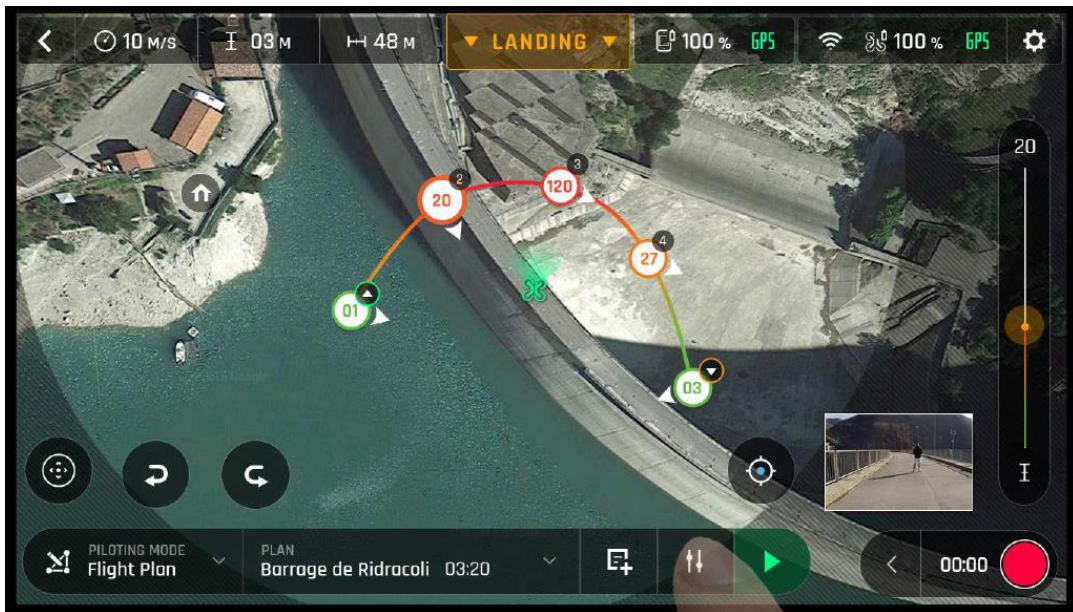

Map backgrounds

Available cartographies: iOS or Android - other cartographies are available upon request.

Fig. 12: iOS map

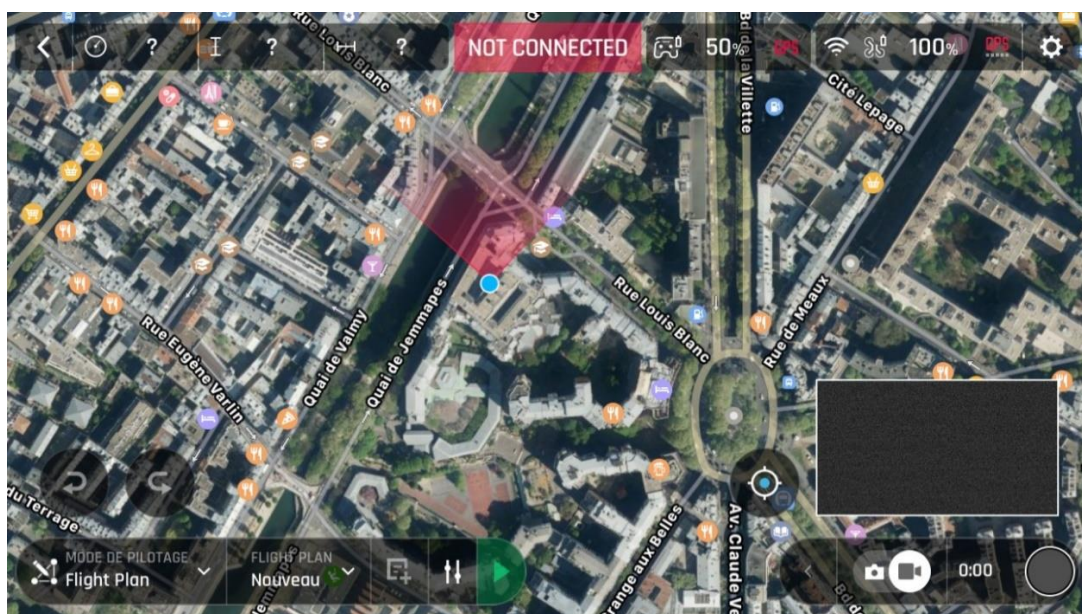

Visualizing media

Media transfer is available directly from ANAFI USA without extracting the microSD card, using an USB cable. Media transfer is also possible directly from the FreeFlight 6.7 gallery to a device. The double gallery of FreeFlight 6.7 separates media stored on ANAFI USA's microSD card and ANAFI USA media downloaded on the device.

Automated updates

FreeFlight 6 updates may also carry one or more of the following updates:

- Drone firmware
- Battery firmware
- GPS
- WIFI chipset firmware
- Parrot Skycontroller 3 controller firmware

GSDK

ANAFI USA's Software development kit (SDK) is available to the public. It contains:

GroundSDK: available for iOS (Swift et Objective C) and Android (JAVA)

The GroundSDK framework allows the user to develop his own mobile applications, based on the controls or the video stream of ANAFI, for example. GroundSDK, including its entire libraries, is available as an open source package, ready to compile – as well as in CocoaPods (iOS) and ARR (Android).

The code is published under BSD-3 license and comes with an installation guide, API documentation, as well as a demo application.

PDrAW: Available on Unix systems (Linux and MacOS)

PDrAW and its suite are a set of software libraries and tools allowing the user to exploit live video stream (RTP) as well as recorded ones (MP4).

PDrAW is used by GroundSDK on Android and iOS and it can be used independently on Linux and MacOS environments.

PDrAW and its suite are available in open source code. The code is published under license BSD-3 and comes with an installation guide and API documentation.

Sphinx Simulator

This software-in-the-loop simulator allows us to simulate ANAFI in 3D in real time. Sphinx is based on the open source robotic simulation framework Gazebo.

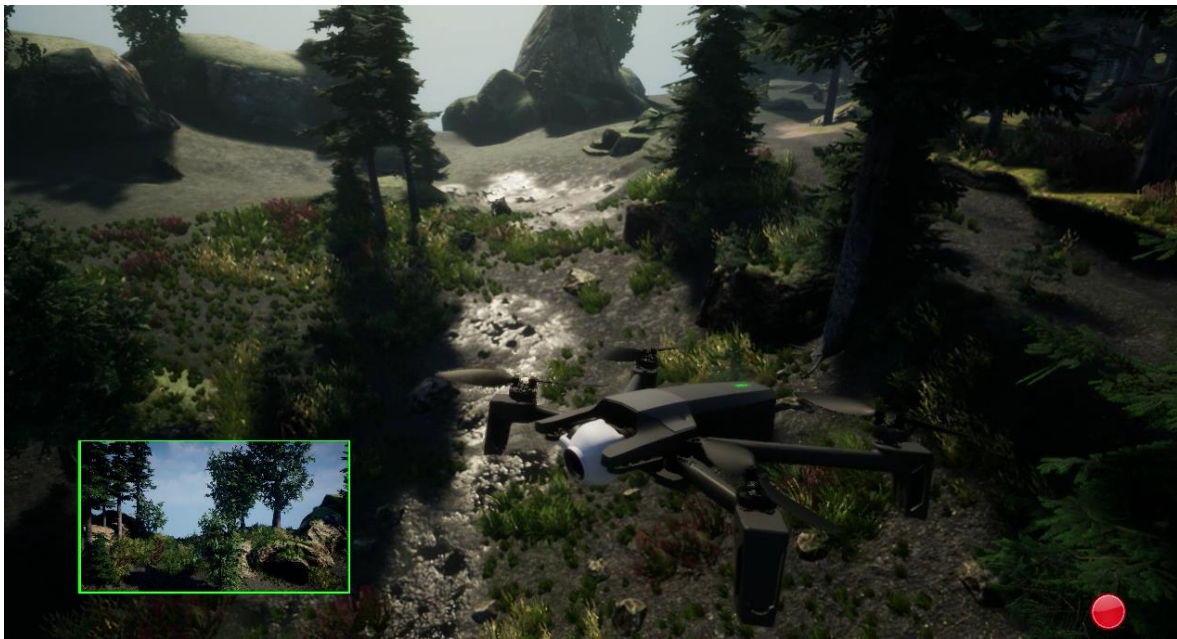
Fig. 13: Sphinx simulator rendering

ANAFI USA's firmware, as simulated on an emulated hardware (camera, sensors and actuators), is identical to ANAFI's actual software. The simulator allows automated testing (headless) and alteration of a hardware peripheral, in real time.

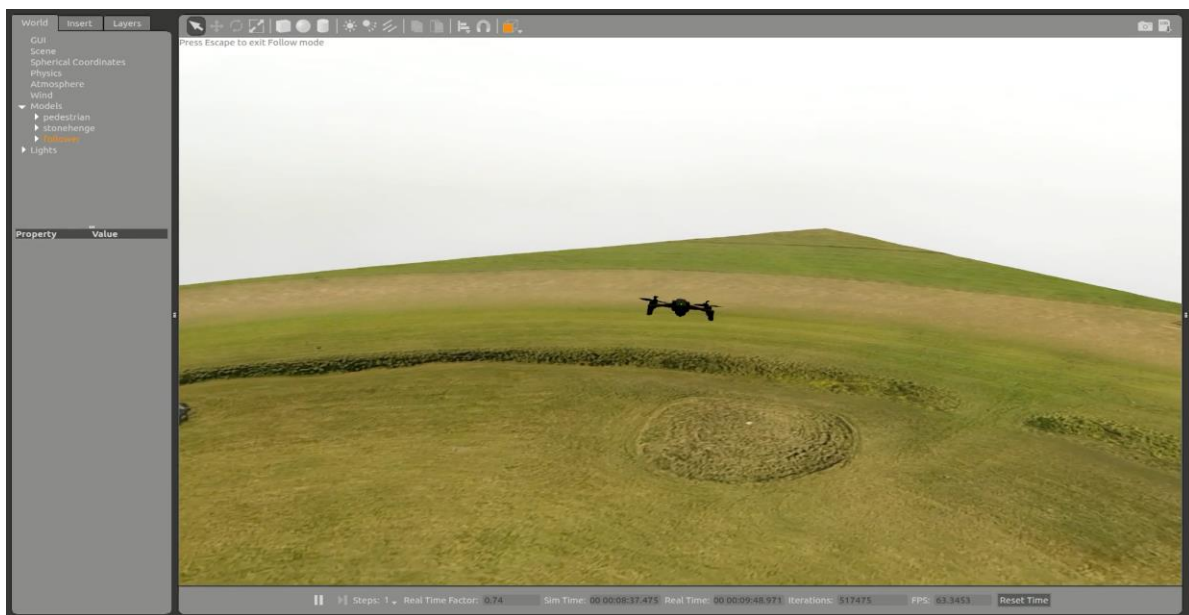
Fig. 14: Sphinx simulator screen capture

MAVLink compatibility

The ANAFI USA platform is compatible with the open source protocol MAVLink v1, that allows real time data exchange between the drone and a control station. ANAFI can be piloted manually or through an automatic flight plan from any MAVLink V1 station, such as QGroundControl.

Fig. 15: MAVLink protocol

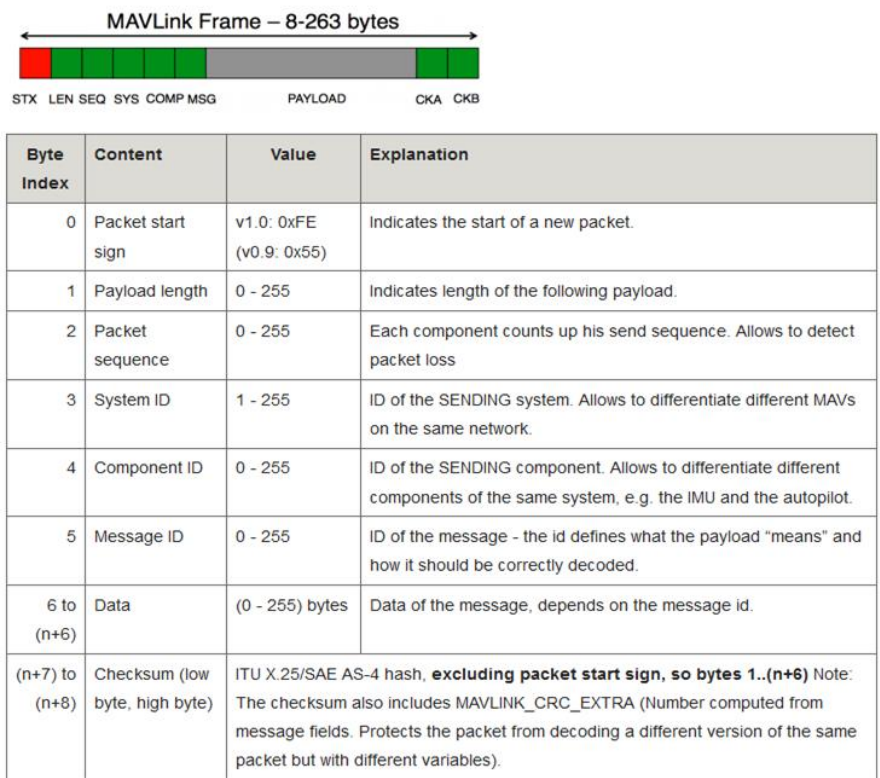
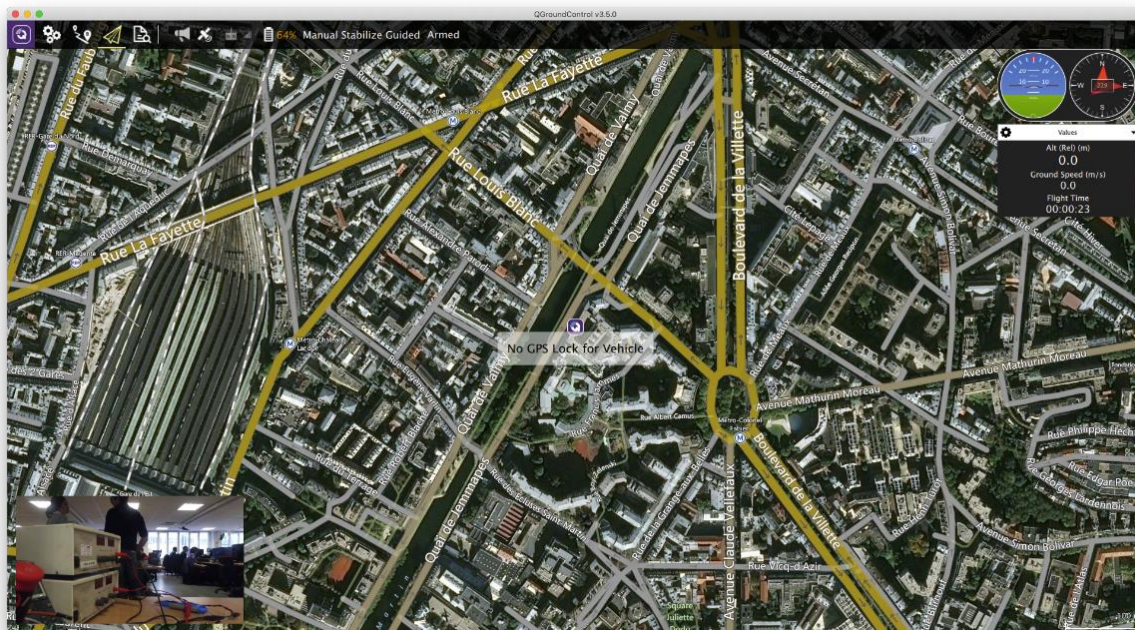

Fig. 16: QGroundControl interface



ANAFI USA compatible tools

ANAFI USA is compatible with the following tools.

Pix4Dreact



Key characteristics

- Pix4Dreact uses ANAFI USA pictures to generate high-resolution, up-to-date and accurate 2D maps, in emergency situations.
- The 2D map is generated on a laptop computer in a few minutes only.
- No Internet connection required.

Pix4Dcapture generates the automatic flight plan which enables ANAFI USA to take the series of captures which compose the map. The images downloaded to the computer are processed automatically to generate the map. When the map is created, users can position markers on it and easily share points of interest. Pix 4Dreact additionally enables the user to measure distances and areas, for the most accurate tactical mission planification.

Fig. 17: Example of 2D map generated by Pix4Dreact

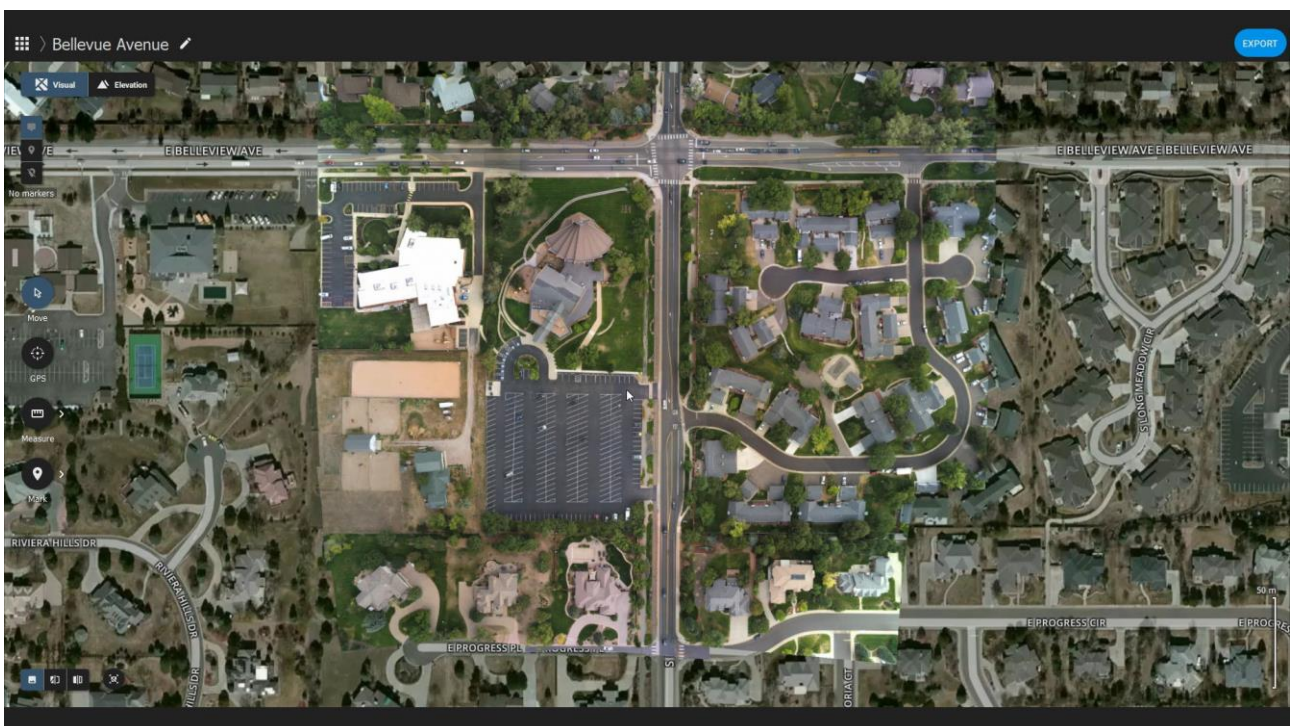

Kittyhawk



Kittyhawk unifies the mission, aircraft, and data to empower safe and effective enterprise drone operations.

Survae



Survae provides a unified way to manage, find and visualize massive sets of video, imagery and data, using maps and timelines as the basis for organization. Use powerful relational, geospatial, temporal, and spatio-hierarchical search to find events, places, and objects from multiple viewpoints.

Planck Aerosystems



Planck Aerosystems believes that autonomous robotic technologies offer revolutionary benefits to many industries. Planck is dedicated to bringing the benefits of drone technology to new applications and markets by making drones simpler, safer, and smarter.

DroneSense



DroneSense is a comprehensive solution that empowers your public safety organization to build, manage, and scale its drone program.

DroneLogbook



Drone data management and flight analysis: DroneLogbook provides a digital document library with custom checklists and risk assessment forms.

Skyward



Skyward's software, services, training, and connectivity provide the next level of operational control for drone programs at every stage. Skyward is a Verizon company.

Hoverseen



Hoverseen is specialized in the deployment of automatic drone-in-a-box solutions.